

Tool List:

- T25 Torx driver

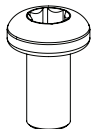

M5x0.8 x 10mm
Pan Head Torx Screw
Qty: 10

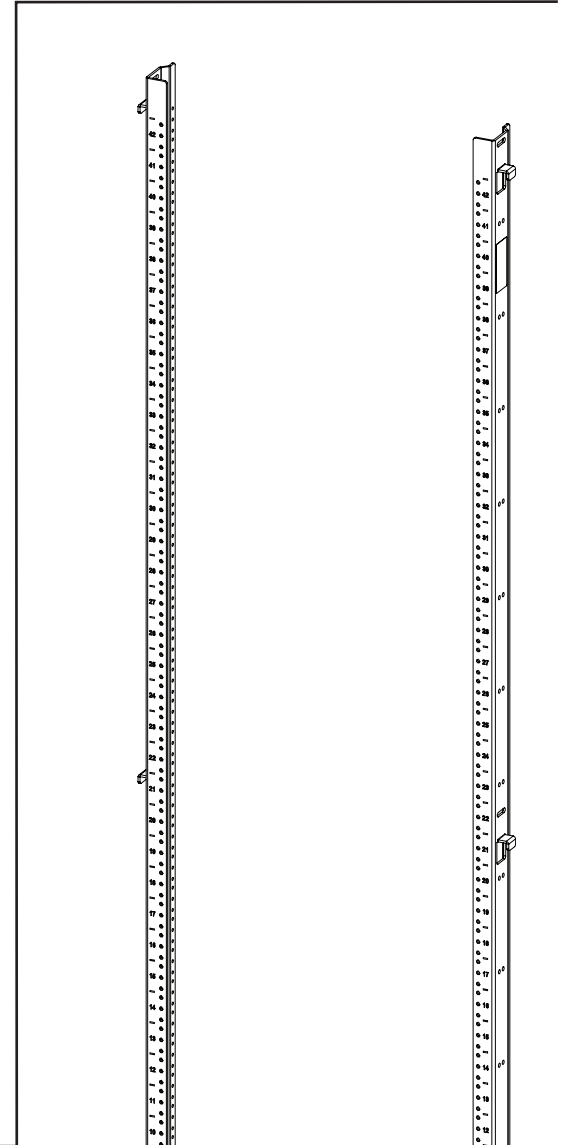
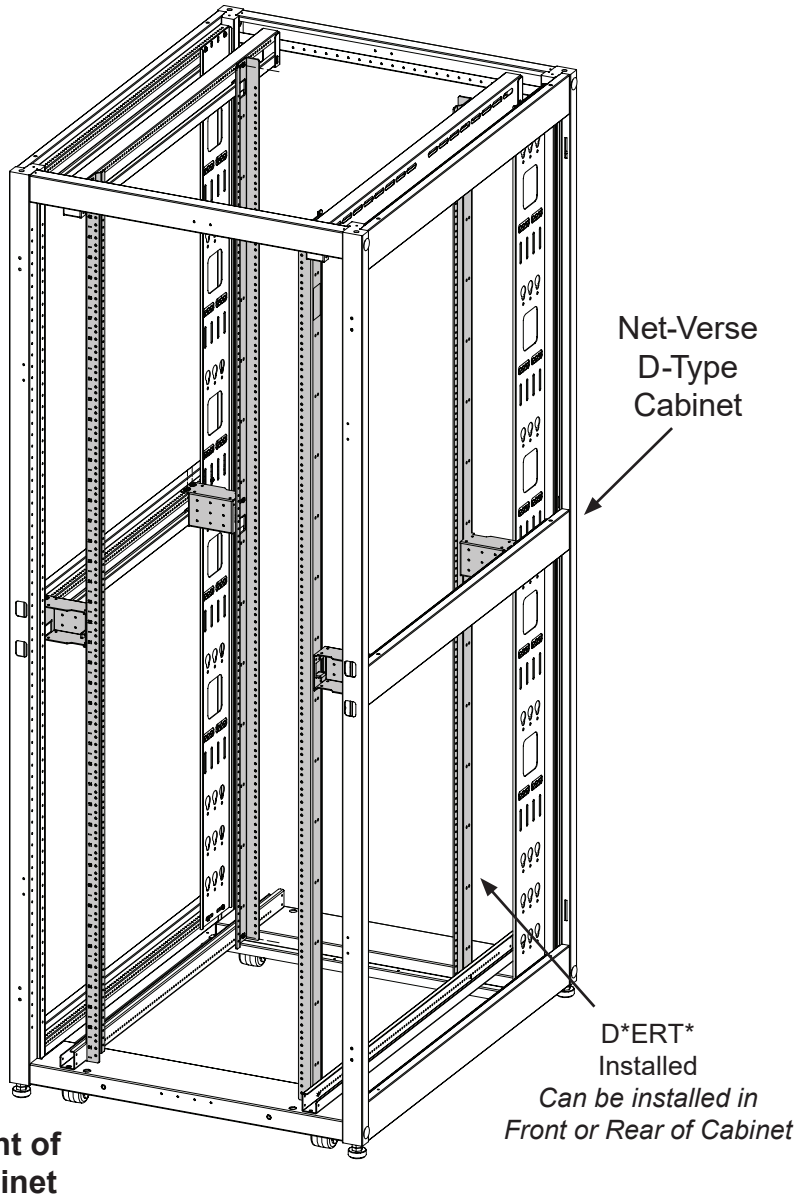
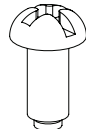

#12-24 x 1/2" UNC
Round Head Screw
Qty: 1 package of 25

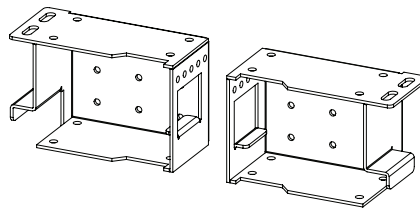

800mm E-Rail Brackets
Qty: 1 Left & 1 Right

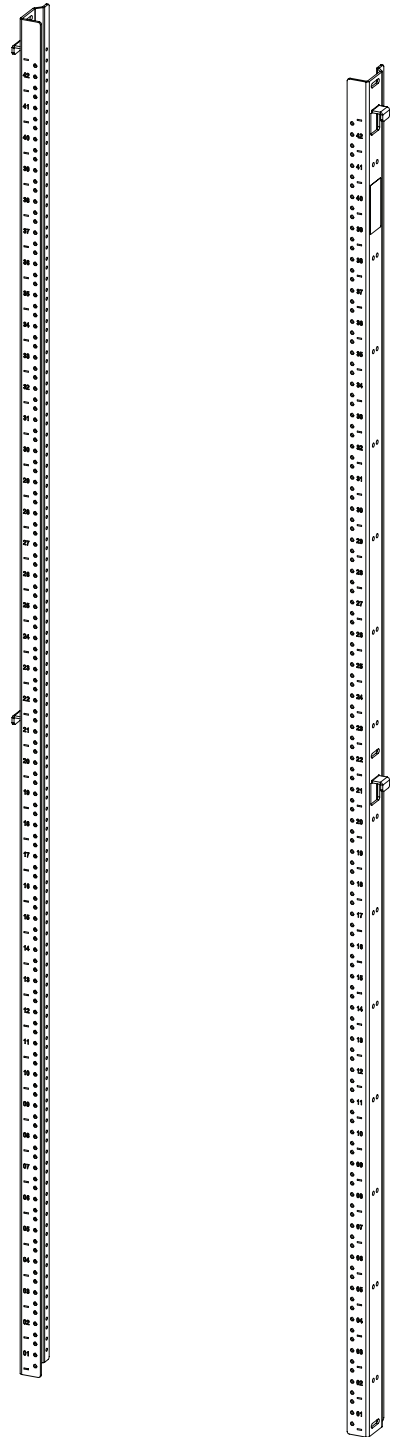

E-Rails
Qty: 1 Left & 1 Right

Remove Standard E-Rails from Cabinets

- Remove the M5 screws from the Standard E-Rails that attach it to the Cabinet were shown.
- Lift E-rail Hooks up and out of the cabinet frame grooves.
- For 800 wide cabinets only, remove the M5 screws from Center Mounting Brackets that attach it to the Cabinet were shown.

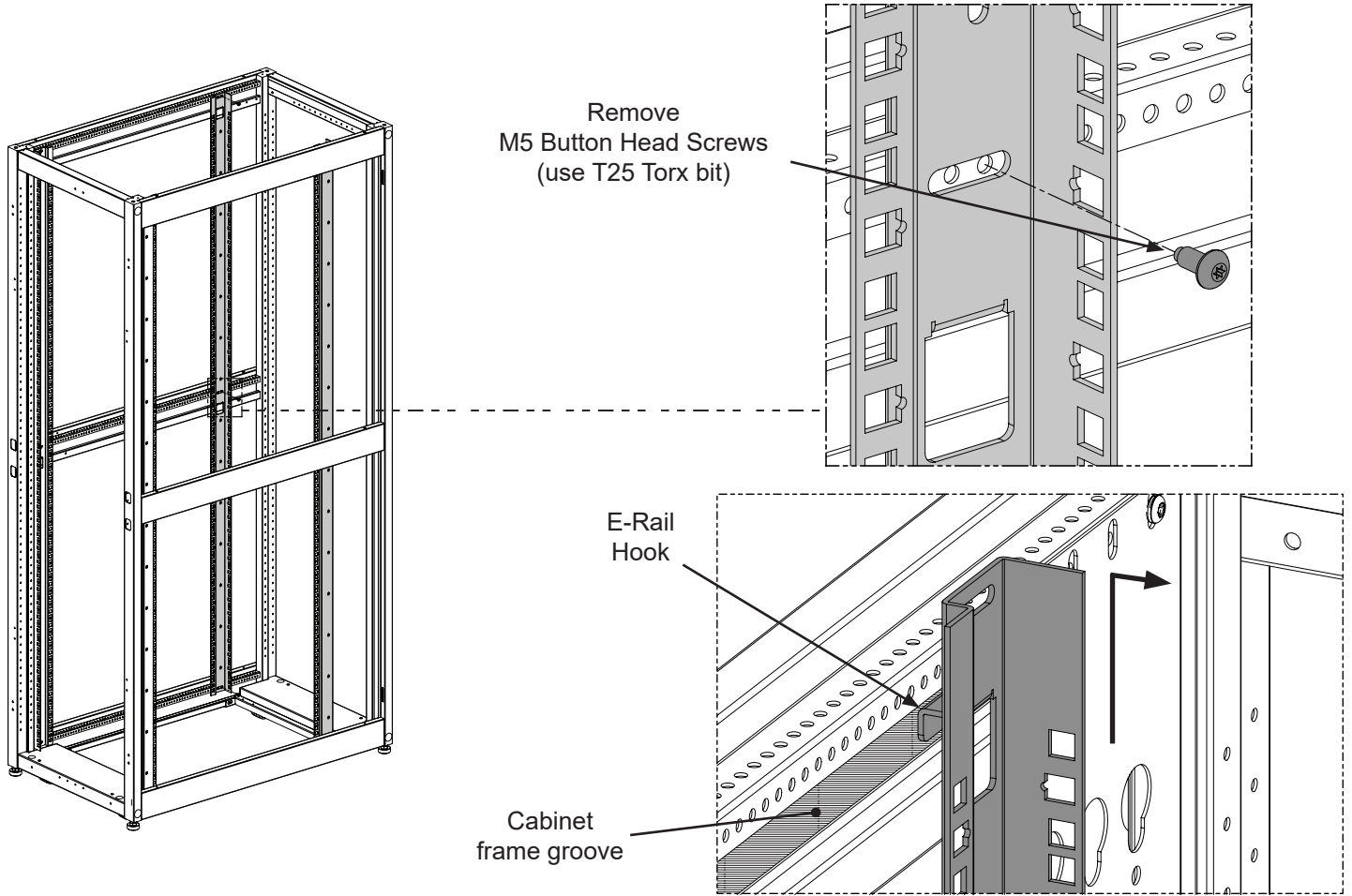

For 800 Wide Cabinets only

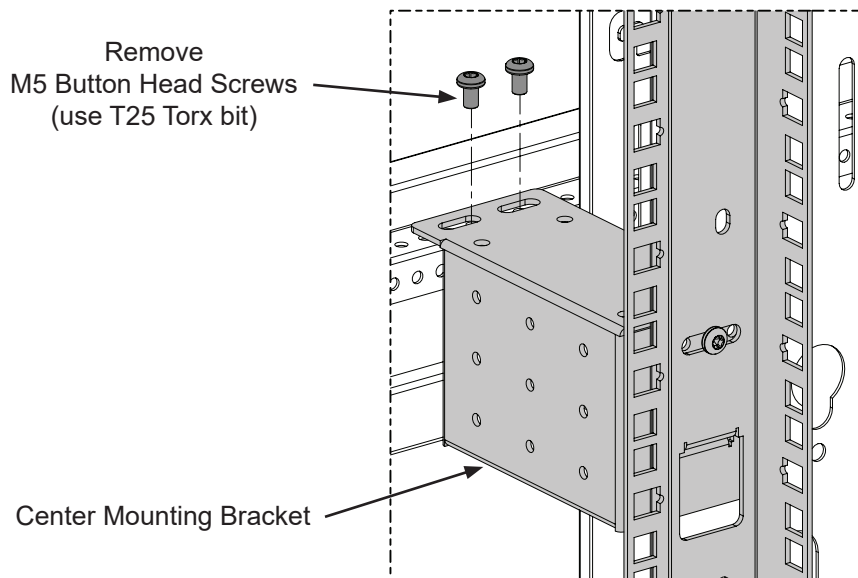

Install E-Rails on 600mm wide Cabinets

- Attach hooks on top and middle of E-Rails into grooves in the Cabinet frame
- Adjust the E-Rails to desired position and secure with M5 screws to $2.7 \pm 0.3 \text{ N}\cdot\text{m}$ [$23.9 \pm 2.7 \text{ in}\cdot\text{lbs}$].

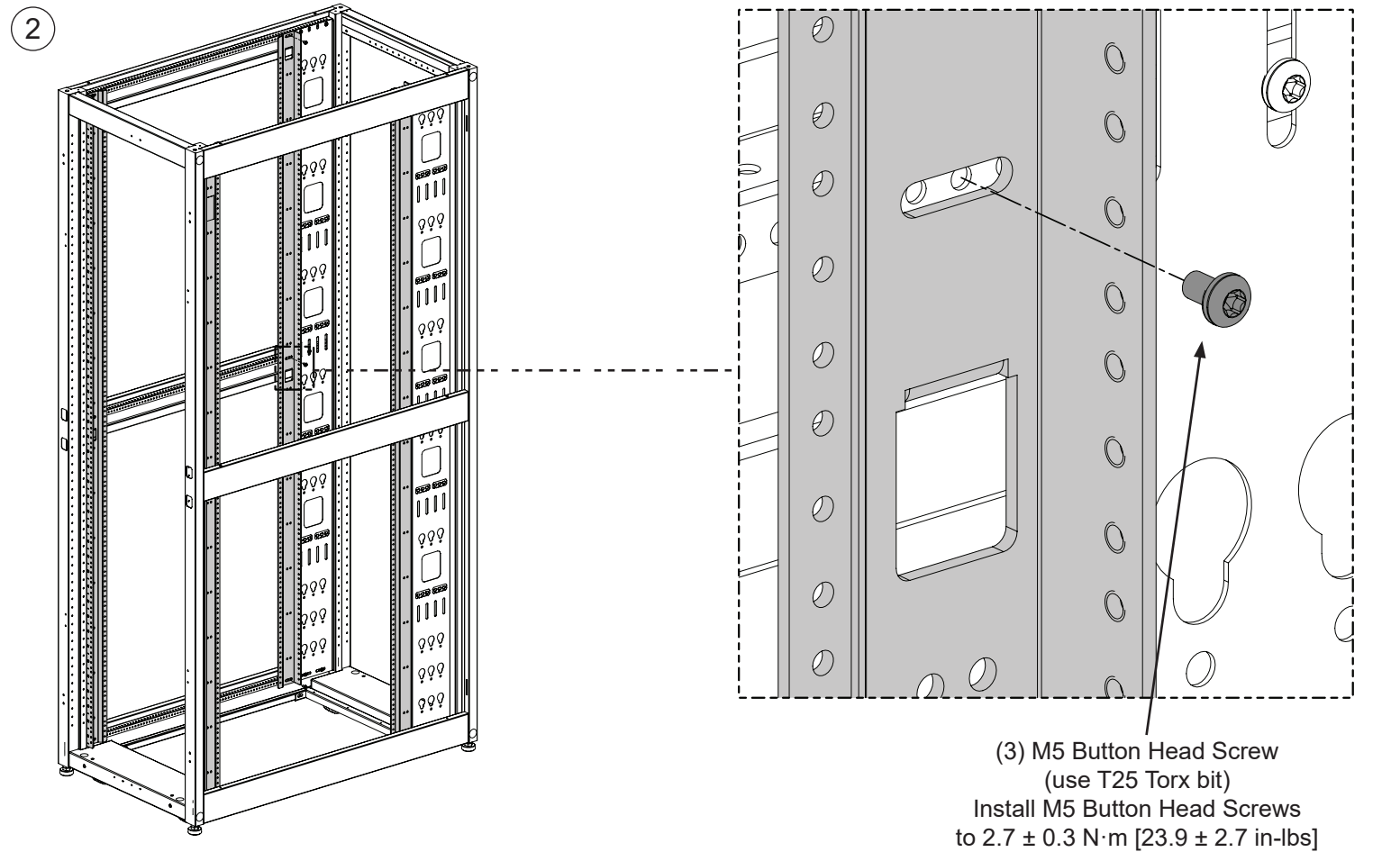
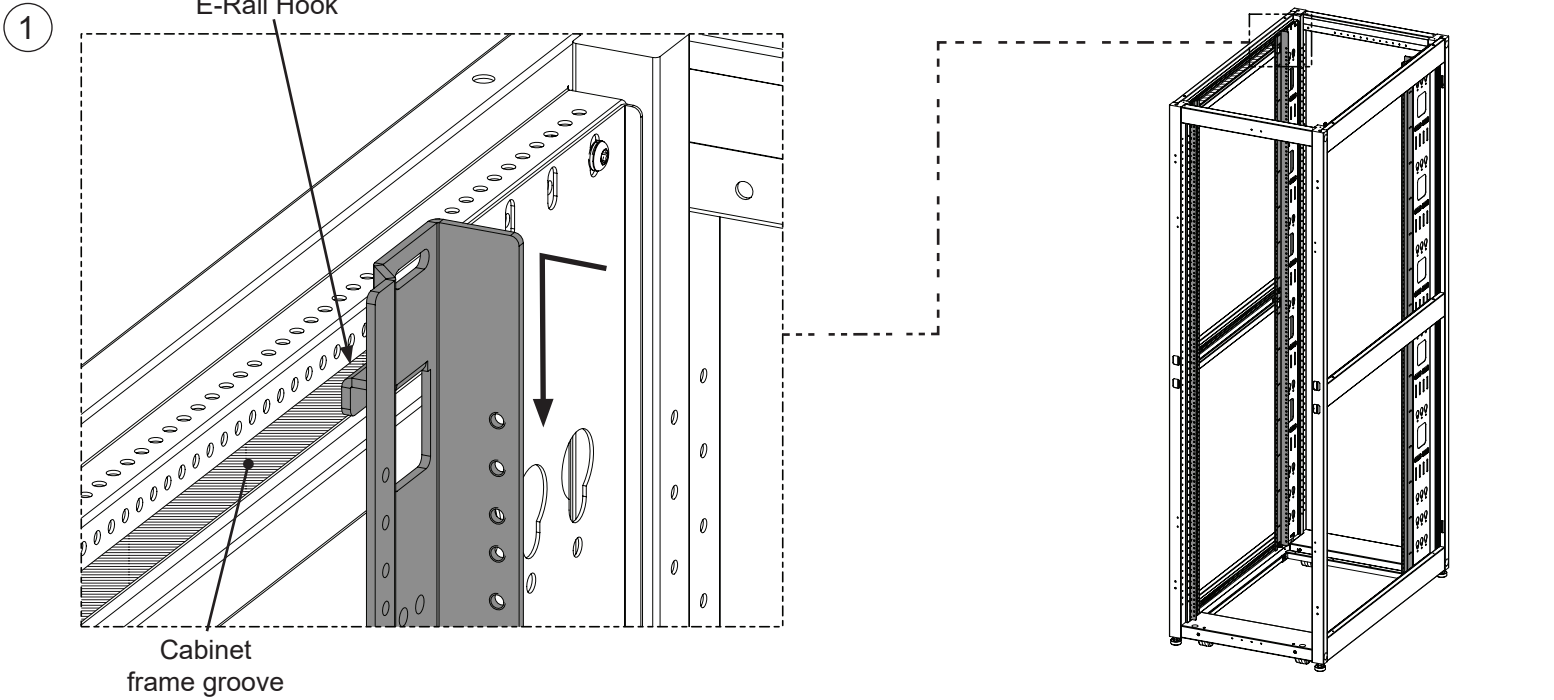

Install E-Rails on 800mm wide Cabinets

- Attach the E-Rail Center Mounting Brackets to the E-Rails with a 3.0mm offset for 800mm Wide Cabinets. Attach with (1) M5 screw tightened to $2.7 \pm 0.3 \text{ N}\cdot\text{m}$ [$23.9 \pm 2.7 \text{ in}\cdot\text{lbs}$] per E-Rail.
- Attach the hooks on top of E-Rails and the Center Mounting Brackets into grooves in the Cabinet frame.
- Adjust the E-Rails to desired position and secure with M5 screws to $2.7 \pm 0.3 \text{ N}\cdot\text{m}$ [$23.9 \pm 2.7 \text{ in}\cdot\text{lbs}$].

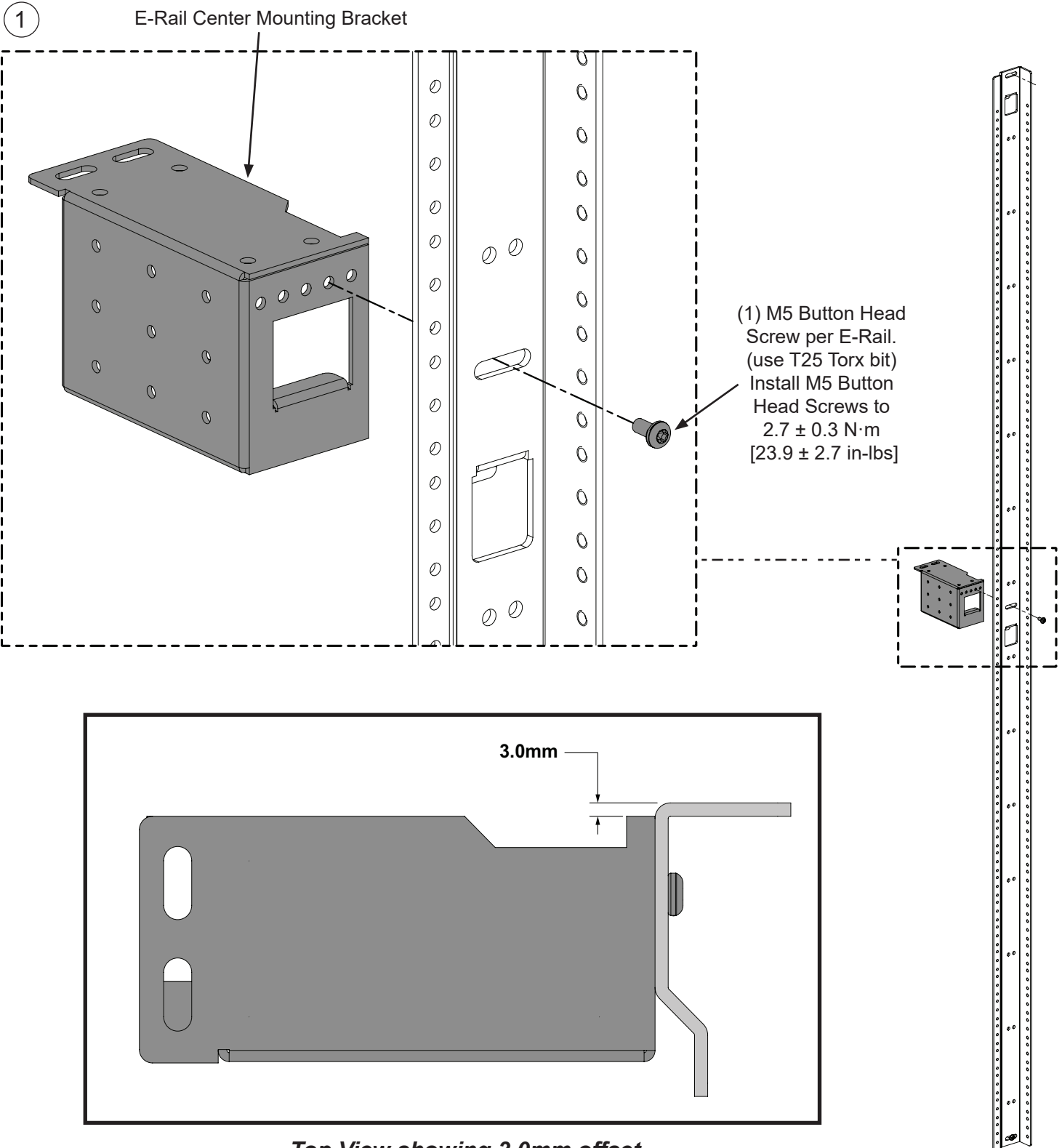

2

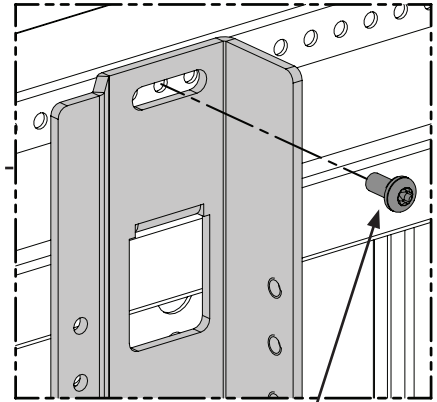
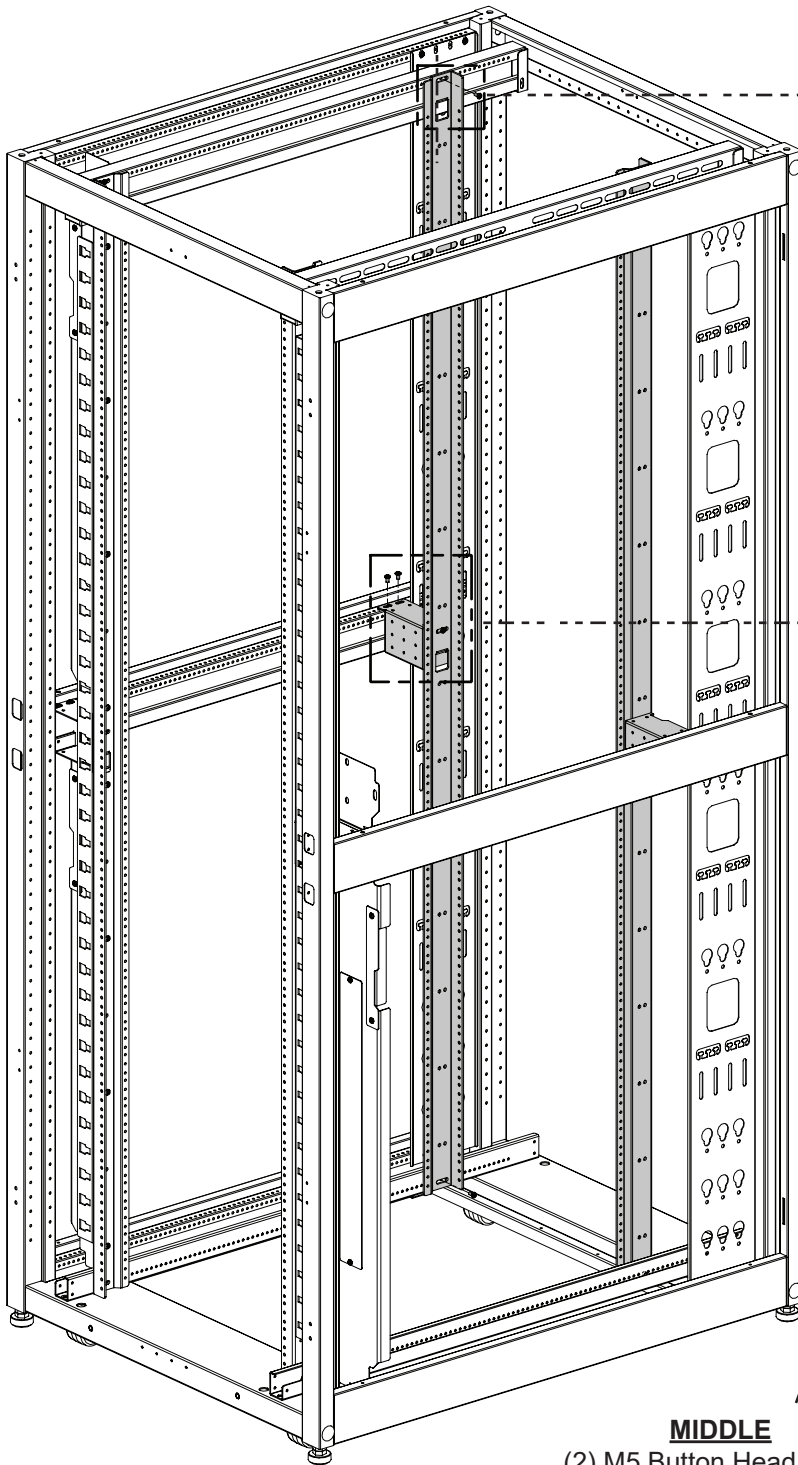

TOP AND BOTTOM
(2) M5 Button Head Screw
(use T25 Torx bit)
Install M5 Button Head Screws
to $2.7 \pm 0.3 \text{ N}\cdot\text{m}$ [$23.9 \pm 2.7 \text{ in}\cdot\text{lbs}$]

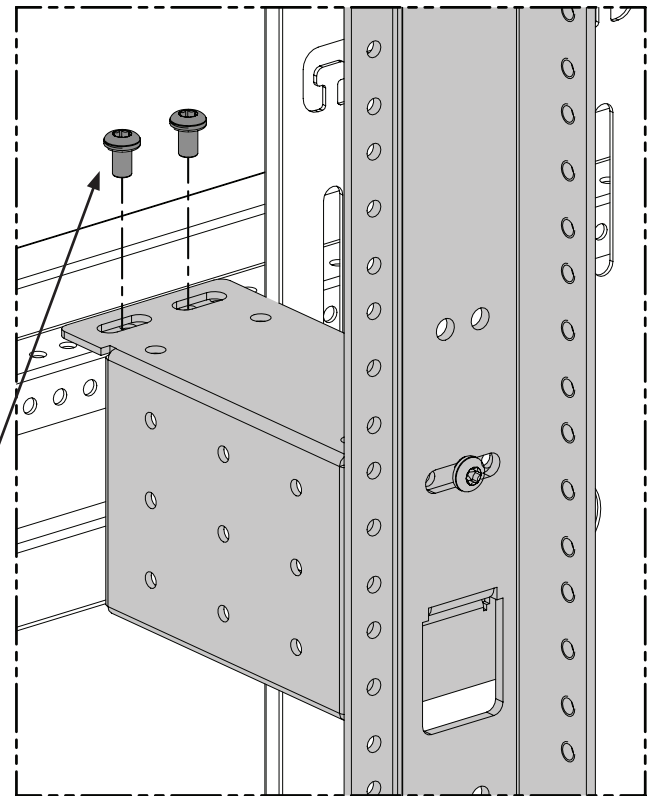

MIDDLE
(2) M5 Button Head Screw
(use T25 Torx bit)
Install M5 Button Head Screws
to $2.7 \pm 0.3 \text{ N}\cdot\text{m}$ [$23.9 \pm 2.7 \text{ in}\cdot\text{lbs}$]

For Instructions in Local Languages
and Technical Support:

www.panduit.com/resources/install_maintain.asp

PANDUIT
www.panduit.com

E-mail:
techsupport@panduit.com

Phone:
866-405-6654